

920mm Winged Console Basin & Legs (Dual heights) (2 or 3 Tap Hole)

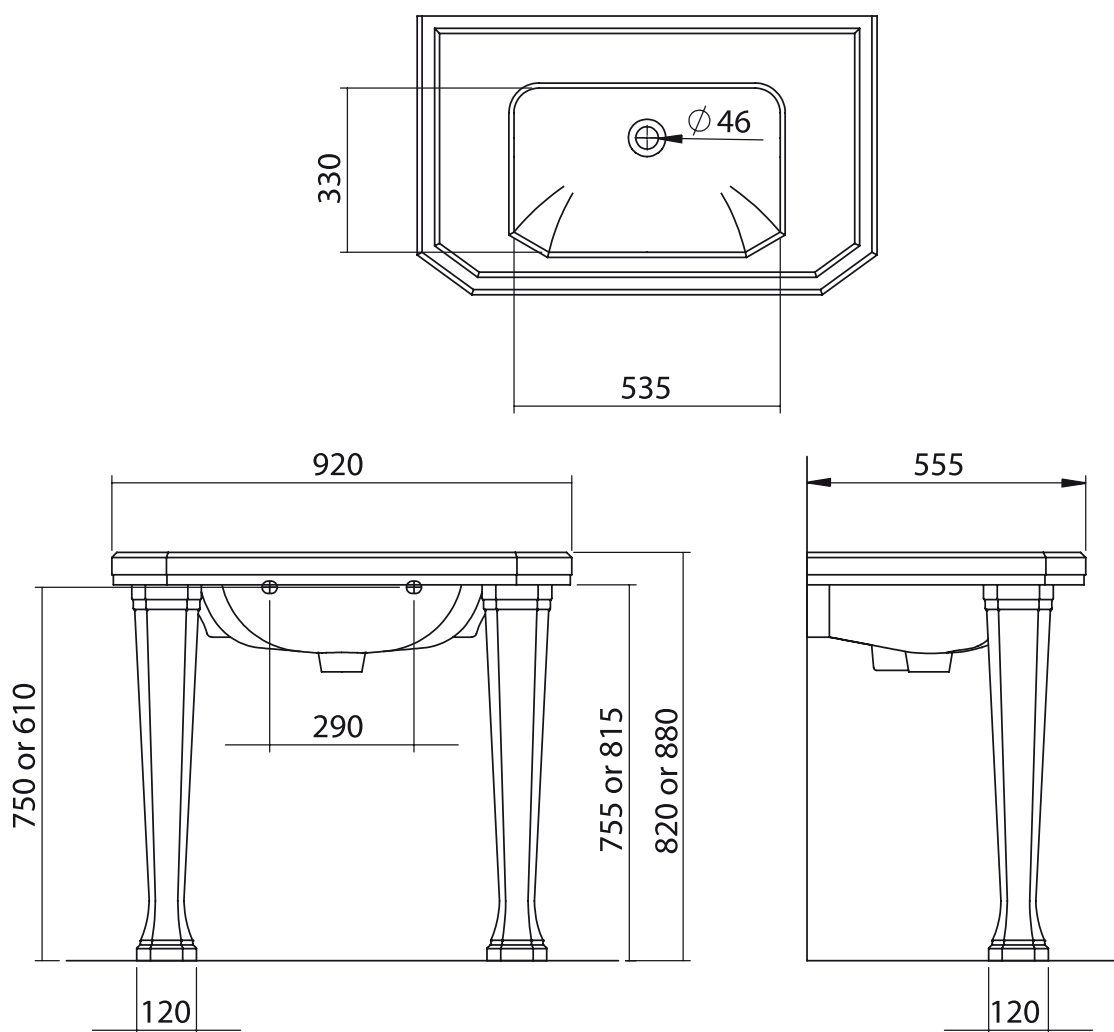

Silverdale Bathrooms Ltd

B.C Sanitan, Silverdale Road, Newcastle Under Lyme, Staffordshire, ST5 6EL.

Telephone: 01782 717175 Facsimile: 01782 717166

Email: sales@silverdalebathrooms.co.uk

www.bcsanitan.co.uk www.silverdalebathrooms.co.uk

